

1 COIL 30 M
 2 COIL 12 M
 3 COIL 12 M
 4 COIL 17 M
 5 COIL 30 M
 6 COIL 30 M
 7 COIL 40 M
 8 COIL 80 M
 9 COIL 160 M
 10 COIL AUX
 11 +12 V
 12 GND

INPUT COILS RXTX RELAYS

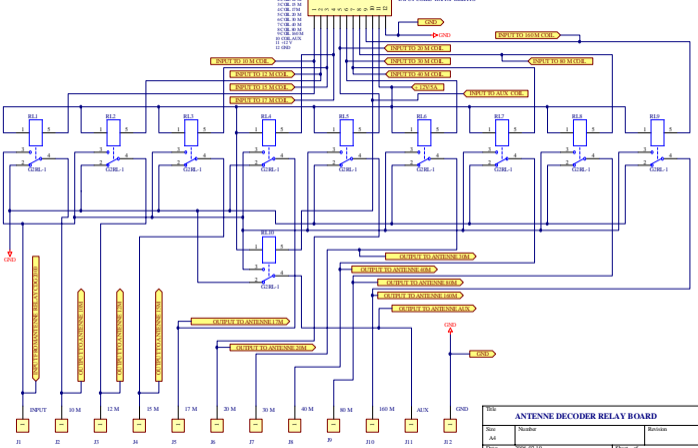

Title		
ANTENNE DECODER RELAY BOARD		
Size	Number	Revision
A4		
Date	2006-02-19	Sheet of
File	D:\PCB_1\DECODER_RELAY_SchDoc	Drawn By: